



# APPLICATION NOTE: 103

## Monitor cold storage rooms with the ThermaViewer

Food manufacturers, distributor, and resellers who store inventory in cold storage rooms need a means of monitoring and documenting the storage conditions. In many cases, their customers want proof of storage conditions when they take delivery of the product. Additionally, most countries have laws dealing with how foods must be stored and the regulatory agencies of these countries want to see the records of the storage temperatures during audits and inspections.

Traditionally this monitoring and documenting was done manually. This required an employee to periodically note the temperature of a cold storage room on a piece of paper. This, of course, did not result in very accurate records since the temperatures could fluctuate when the employee was not looking at the thermometer. Many businesses now use chart recorders to record the temperature twenty-four hours a day, seven days a week. They are much better than a manual system, but they still have serious drawbacks. They have moving parts, which means that they eventually wear out. But the real problem is that someone has to change the chart and pen frequently, the charts are hard to interpret, and they must be stored in filing cabinets or boxes. This can get time consuming and expensive.

A much better solution is the [ThermaViewer](#). It has two probes, which can track two different storage rooms or two different locations in the same room. It stores over 10 months of temperatures for each probe if set to store a temperature every ten minutes, the data can be archived electronically, and the charts are very easy to read. The ThermaViewer can be used with digital sensors, thermistors if high accuracy is needed, or thermocouples if very cold temperatures must be monitored

Using a ThermaViewer is simple, with minimum set-up time required. It needs no programming, maintenance, no paper or pens. Simply plug the ThermaViewer into a wall socket and begin collecting temperature information immediately.

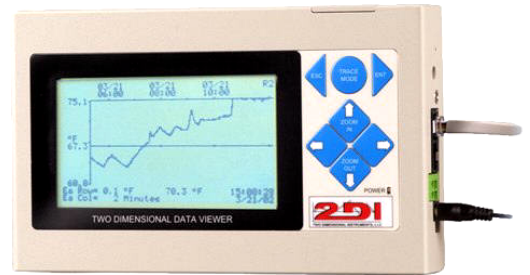

**ThermaViewer**

Installation of the ThermaViewer is a simple 5 step process:

1. Position the two sensor modules in the cooler and freezer to be monitored.
2. Route and Plug in the two 20 foot cables (100 foot cables are available as an option).
3. Plug the power adaptor into a wall socket and into the ThermaViewer.
4. Attach the auto dialer (if purchased).
5. Set the time and monitoring frequency (see below for suggested settings).

**What to Order:**

- TDVD-01 ( $\pm 1^{\circ}\text{C}$ ) digital sensors \$ 549.00

**Optional Items:**

- TDVD-02 ( $\pm 0.2^{\circ}\text{C}$ ) Thermistors \$ 649.00
- TDVD-05 thermocouples \$ 649.00
- Auto-dialer with cable \$ 169.00
- 100 foot cable \$ 45.00

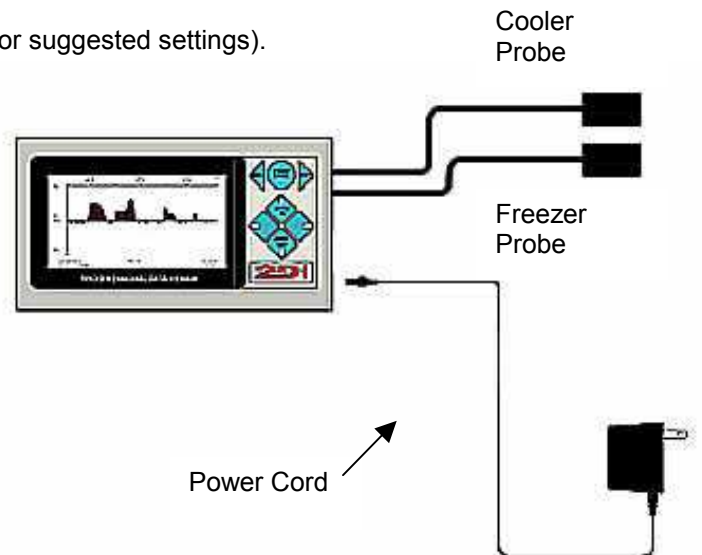

Order from your [local distributor](#) or:

**Two Dimensional Instruments**



## APPLICATION NOTE: 103

### Installation and Setup

Mount the ThermaViewer display unit near the cold storage rooms. The probes are normally placed about ½ way up from the floor and about ½ way back inside the unit to monitor the average temperature maintained within that appliance, although some agencies want the probe placed near the door.

The following are suggested settings for the ThermaViewer. You should use the settings required by your standards called for in your HACCP plan.

#### Suggested settings:

Freezer Probe		Cooler Probe	
Sample Data every	15 seconds	Sample Data every	15 seconds
Store Data every	10 minutes	Store Data every	10 minutes
Recorded Temperature	Average	Recorded Temperature	Average
Temperature Scale	F°	Temperature Scale	F°
Maximum Display Temperature	10°	Maximum Display Temperature	50°
Minimum Display Temperature	-40°	Minimum Display Temperature	30°
Reference Line	-20°	Reference Line	41°
Relay Enabled <sup>1</sup>		Relay Enabled <sup>1</sup>	
Activate Relay for	0:10 (min:sec)	Activate Relay for	0:10 (min:sec)
When Temp >	-10° for 6 stored temperatures	When Temp >	49° for 6 stored temperatures
When Temp <	-40° for 6 stored temperatures	When Temp <	31° for 6 stored temperatures

Setting the probes to sample data every 15 seconds and store data every 10 minutes causes the [ThermaViewer](#) to take forty samples then plot and store the average of those forty readings. This causes the graph to more accurately reflect the internal temperature of the stored food rather than the air temperature of the cooler or freezer. Momentary dips and rises of the air temperature are not enough to affect the actual food temperature and can safely be averaged over the 10 minute period between readings.

#### [Downloading data:](#)

The ThermaViewer will hold ten months of temperature data for each probe with the settings listed above. A regular schedule for downloading data from the ThermaViewer should be established so that an archived copy of the data is maintained in your computer. You can also print out a copy of the graph if you really have to have a paper record.

The ThermaViewer can automatically upload real time data to an office computer if wired to a serial port on that computer. If the TView program is set to upload automatically, it will display a graph of the temperature history and write the data to a file on that computer. The file name will be prefixed with the month and year of the data and will automatically begin a new file at the start of each month.

<sup>1</sup> Enable the relay only if you have an alarm or the optional auto-dialer wired to the relay. See note 201