

APPLICATION NOTE: 204

Using the ThermaViewer to monitor temp/rh in clean rooms.

It is critical that the temperature and humidity be monitored and documented in clean rooms.

Clean rooms normally have temperature/RH limits for manufacturing, assembly, and testing. Abnormal temperature and humidity can interfere with these processes, resulting in high reject rates and loss of product. High humidity and/or temperature conditions can cause some instruments to go out of calibration, whereas low humidity facilitates the generation of static electricity, which can destroy not only product but delicate instruments as well. Additionally, ISO 9000 standards may require continuous monitoring and documentation of temperature and humidity.

The ThermaViewer is an ideal instrument for monitoring and documenting the temperature and humidity of isolated clean rooms. It is equipped with two temperature/RH sensors ($\pm .2^{\circ}\text{C}$ & $\pm 2\%$), to monitor and document temp/RH in two different rooms or two areas of the same room.

It is accurate and automatic, continuously monitoring and indicating trends so that corrective action can be taken. Temperature and humidity data is displayed as a chart on the large LCD display. A trace mode and a zoom function lets anyone examine individual readings as well as look at overall trends. It requires no special skills to read and interpret the data and comes equipped with a dry-contact relay to trigger an alarm or auto dialer if out-of-spec conditions occur.



[ThermaViewer](#)

Using a ThermaViewer is simple, with minimum set-up required. It needs no programming, maintenance, paper or pens to monitor and document temperature and humidity over time. Simply plug the ThermaViewer into a wall socket and begin collecting temperature/RH data immediately.

Installation of the ThermaViewer is a simple 5-step process:

1. Position the two sensor modules in the areas to be monitored.
2. Route and plug in the two 20 foot cables (100 foot cables are available as an option).
3. Plug the power adaptor into a wall socket and into the ThermaViewer.
4. Attach the auto dialer (if purchased).
5. Set the time and monitoring frequency (see below for suggested settings).

What to Order:

- TDVDR-02 ($\pm .2^{\circ}\text{C}$) \$ 749.00

Optional Items:

- TDVD-02 ($\pm 0.1^{\circ}\text{C}$) \$ 799.00
- Auto-dialer with cable \$ 169.00
- 100 foot cable \$ 45.00

Order from your [local distributor](#) or:

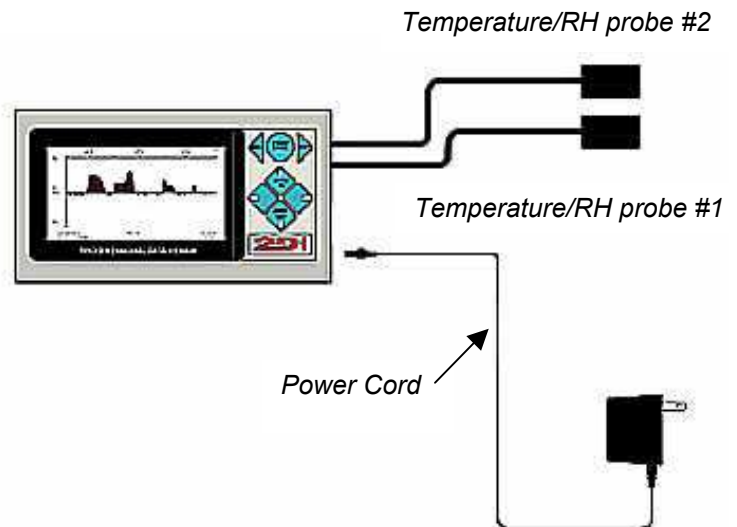



APPLICATION NOTE: 204

Installation and setup

Mount the ThermaViewer display unit in the room or office area near the area to be monitored. Position each probe in a separate space and attach the auto dialer (if purchased) to the relay connection.

The following are suggested settings. You should use the settings required by your standards.

Suggested settings:

Room 1 Probe		Room2 Probe	
Sample Data every	15 seconds	Sample Data every	15 seconds
Store Data every	10 minutes	Store Data every	10 minutes
Recorded Temperature	Average	Recorded Temperature	Average
Temperature Scale	F°	Temperature Scale	F°
Maximum Display Temperature	80°	Maximum Display Temperature	80°
Minimum Display Temperature	60°	Minimum Display Temperature	60°
Reference Line	70°	Reference Line	70°
Relay Enabled ¹		Relay Enabled ¹	
Activate Relay for	0:10 (min:sec)	Activate Relay for	0:10 (min:sec)
When Temp > 80° for 6 stored temperatures		When Temp > 80° for 6 stored temperatures	
When Temp < 60° for 4 stored temperatures		When Temp < 60° for 4 stored temperatures	

Setting the probes to sample data every 15 seconds and store data every 10 minutes causes the ThermaViewer to take forty samples then plot and store the average of those forty readings. This causes the graph to more accurately reflect the temperature and humidity of the room. Momentary dips and rises of the air temperature and humidity, which can occur are not usually enough to affect the internal environment and can safely be averaged over the 10 minute period between readings. The ThermaViewer will hold ten months of temperature/RH data for each probe with the settings listed above (10 minute store interval). If you want to hold more data you can lengthen the store data interval. An interval of 60 minutes will allow five years of data to be stored for each sensor.

There is a one-point temperature and RH characterization table built into the ThermaViewer that can be used to adjust the temperature and RH readings. The sensors used with the ThermaViewer should remain in calibration for years, however is they do drift; it is not necessary to send the sensors back to the factory for recalibration.

On the System Parameter menu, an 'offset' value can be keyed in to adjust each temperature and RH reading. An offset up to $\pm 9.9^\circ\text{F}$ for temperature and $\pm 9.9\%$ for humidity can be entered for each temperature and RH sensor. The offset will be added or subtracted to or from the measured value of each sensor before it is stored in memory or displayed on the LCD display. (Each sensor should be compared to a calibrated instrument traceable to NIST standards, by a qualified metrologist before adjusting this value).

Downloading data:

A regular schedule for downloading data from the ThermaViewer should be established so that a back up copy of the data is maintained in your computer. You can also print out a copy of the graph with the same program that downloads data to your computer (TView).

¹ Enable the relay only if you have an alarm or the optional auto-dialer wired to the relay. See note 102