



# APPLICATION NOTE: 91

## Monitoring temperature of a computer room

It can be critical that the room temperature of computer rooms be monitored.

Many servers now have internal fans which do a good job of keeping themselves cool but the room environment could be getting warmer and warmer endangering other equipment and creating an environment where stored data could be in danger of being corrupted.

The ThermaViewer paired with the optional auto dialer will insure that you are notified if the room temperature begins to creep up into the danger zone. It is equipped with one or two digital temperature probes ( $\pm 1.5^{\circ}\text{C}$ ), to monitor and document temperature in two different rooms or two areas within the same room. Its onboard dry contact relay triggers the optional auto dialer to call four different phone numbers if the temperature gets too hot or cold.

It is accurate and automatic, providing continuous monitoring so that if you do receive an alert you have an exact record of the temperature so that you can tell immediately when the temperature began to rise, how high or low it got and how long it has been there. The temperature data is displayed as a chart on the large LCD display. It has a trace mode and a zoom function so that individual measurements as well as trends can be examined. It requires no special skills to read and interpret and comes equipped with a relay to trigger an alarm or auto dialer if out-of-spec conditions occur.

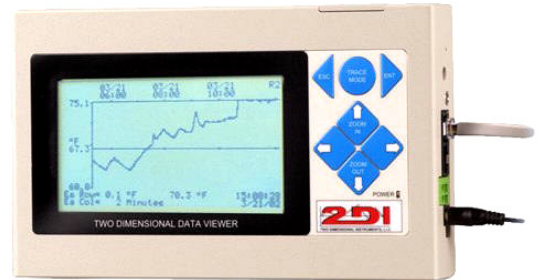

**ThermaViewer**

Using a ThermaViewer is simple, with minimum set-up required. It needs no programming, maintenance, paper or pens to monitor and document temperature. Simply plug the ThermaViewer into a wall socket and begin collecting temperature history immediately.

Installation of the ThermaViewer is a simple 5-step process:

1. Position the sensors in the areas to be monitored.
2. Route and plug in the two 20 foot cables (100 foot cables are available as an option).
3. Plug the power adaptor into a wall socket and into the ThermaViewer.
4. Attach the auto dialer (if purchased).
5. Set the time and monitoring frequency (see below for suggested settings).

### What to Order:

- TDVD-01 ( $\pm 1.5^{\circ}\text{C}$ ) \$ 549.00
- TDVD-01-1 ( $\pm 1.5^{\circ}\text{C}$ ) 1 probe \$ 499.00

### Optional Items:

- TDVD-02 ( $\pm 0.2^{\circ}\text{C}$ ) \$ 649.00
- Auto-dialer with cable \$ 189.00
- Local alarm (siren & strobe) \$ 50.00
- 100 foot cable \$ 50.00
- International Power supply \$ 30.00 (100-240vac 50-60hz)

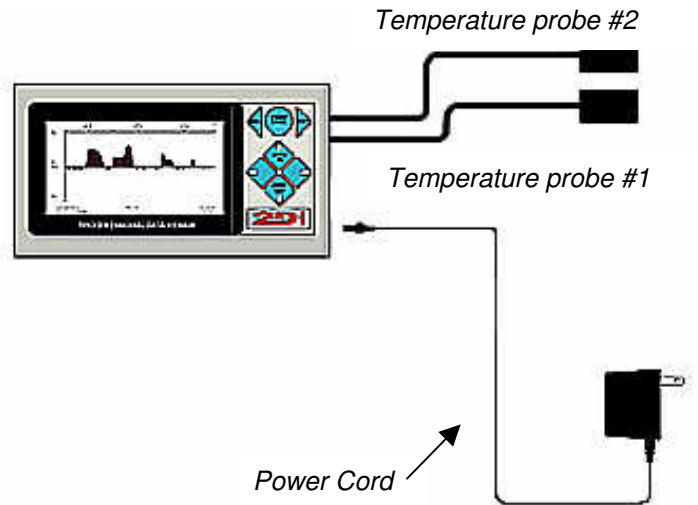



# APPLICATION NOTE: 91

## Installation and setup

Mount the ThermaViewer display unit in the room or office area near the area to be monitored. Position each probe in a separate space and attach the auto dialer (if purchased) to the relay connection.

*The following are suggested settings. You should use the settings required by your standards.*

### Suggested settings:

Room 1 Probe		Room 2 Probe	
Sample Data every	15 seconds	Sample Data every	15 seconds
Store Data every	10 minutes	Store Data every	10 minutes
Recorded Temperature	Average	Recorded Temperature	Average
Temperature Scale	F°	Temperature Scale	F°
Maximum Display Temperature	80°	Maximum Display Temperature	80°
Minimum Display Temperature	60°	Minimum Display Temperature	60°
Reference Line	70°	Reference Line	70°
Relay Enabled <sup>1</sup>		Relay Enabled <sup>1</sup>	
Activate Relay for	0:10 (min:sec)	Activate Relay for	0:10 (min:sec)
When Temp > 80°	for 6 stored temperatures	When Temp > 80°	for 6 stored temperatures
When Temp < 60°	for 4 stored temperatures	When Temp < 60°	for 4 stored temperatures

Setting the probes to sample data every 15 seconds and store data every 10 minutes causes the ThermaViewer to take forty samples then plot and store the average of those forty readings. This causes the graph to more accurately reflect the temperature of the room. Momentary dips and rises of the air temperature, which can occur when a door is opened are not usually enough to affect the internal environment and can safely be averaged over the 10 minute period between readings.

There is a one-point temperature characterization table built into the ThermaViewer that can be used to adjust the temperature. The sensors used with the ThermaViewer should remain in calibration for years, however is they do drift; it is not necessary to send the sensors back to the factory for recalibration. On the System Parameter menu, an 'offset' value can be keyed in to adjust each temperature reading. An offset up to  $\pm 9.9^{\circ}\text{F}$  for temperature can be entered for each of the two temperature sensors. The offset will be added or subtracted to or from the measured value of each sensor before it is stored in memory or displayed on the LCD display. (Each sensor should be compared to a calibrated instrument traceable to NIST standards, by a qualified metrologist before adjusting this value).

#### Downloading data:

The ThermaViewer will hold ten months of temperature data for each probe with the settings listed above (10 minute store interval). If you want to hold more data you can lengthen the store data interval. An interval of 60 minutes will allow five years of data to be stored for each sensor.

A regular schedule for downloading data from the ThermaViewer should be established so that a back up copy of the data is maintained in your computer. You can also print out a copy of the graph with the same program that downloads data to your computer (TView).

<sup>1</sup> Enable the relay only if you have an alarm or the optional auto-dialer wired to the relay. 3

# APPLICATION NOTE: 102



## Optional Auto-Dialer

The ThermaViewer comes equipped with a dry-contact relay that can be used to trigger an alarm or auto dialer. Each probe has its own high and low trigger point. The relay will be closed when temperature rises above 80°F for more than 60 minutes or falls below 60°F for more than 40 minutes, if the suggested settings above are used. Once the relay has been triggered, the alert clock is reset. Therefore in this example, after the relay is triggered, the temperature will have to rise above 80°F for more than 1 hour or falls below 60°F for more than 40 minutes before the relay will be triggered again.

If you need faster response time you can decrease the number of stored temperatures in the probe menus. Setting this value for 1 instead of 6 will result in triggering the relay if one measurement is above or below the set values.

If an auto dialer is ordered with a ThermaViewer, a power supply with two leads is supplied to provide power for both the ThermaViewer and the auto-dialer. The auto dialer will call four phone numbers (i.e. phone, pager, answering machine or service) and leave a 16 second message when triggered by the ThermaViewer. It will keep calling the four numbers until someone picks up and the message is delivered.

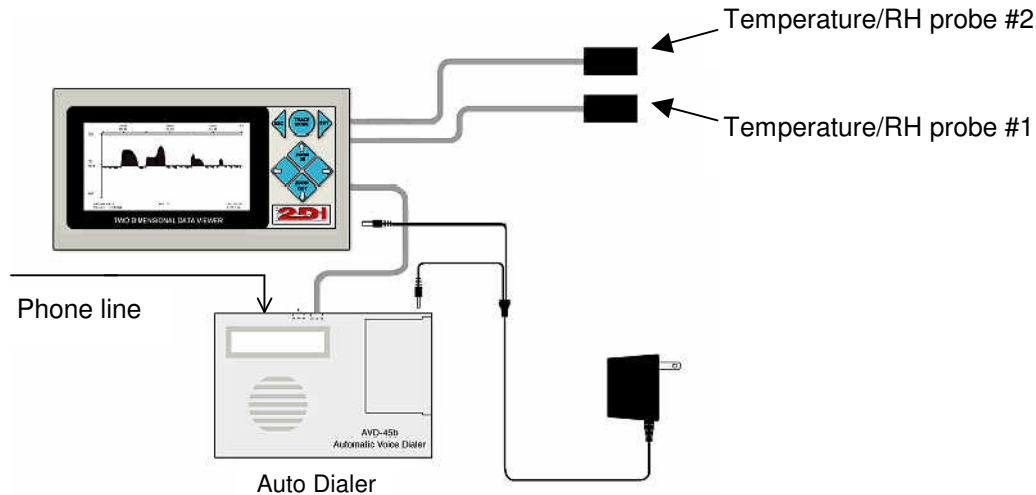

The auto dialer should be set as follows:

- 60 second exit delay
- 20 second entry delay
- N.O. (meaning that the relay is normally open).
- MOM (meaning that it only takes a momentary activation from the relay to trigger the dialer).

A relay test function on the System Parameter of the ThermaViewer causes the relay to be immediately triggered. Entering 'yes' in this field causes the ThermaViewer causes the auto dialer to immediately call the four phone numbers stored in its memory. Allow 90 seconds to elapse between the time you exit the programming mode of the auto dialer and you activate the relay.

**Technical support for Auto Dialer only (858) 413-0149**